

UPM310

DIN 96x96 and ANSI 4" Power Meter



- DIN 96 & ANSI 4" Cutout for New or Retrofit Applications
- Fully Bi-Directional Four Quadrants Readings
- Neutral Current Monitoring
- Up to Two Plug-In Option Boards
- Large and Bright LED Alphanumeric Display
- UL Recognized Under UL61010B-1 and CAN/CSA-C22.2 No.1010.1-92, File #E231725
- Power and Current Demand Calculation During User-Definable Time Period
- THD and Individual FFT Harmonic Analysis up to 31st Order
- On-Board Memory up to 2MB
- Programmable Min/Avg/Max & Energy Data Logging
- Event and Alarm Recording



General Description

The UPM310 is a multifunction metering device suitable to measure the electrical parameters.

It provides accurate True RMS measurements on bright LED display, or via serial communication port.

The power meter replaces multiple existing analog meters as well as all single function meters or transducers. The powerful capabilities offered by the instruments make it ideal for stand-alone metering or energy management systems.

The UPM310 offers a compact unit together with a variety of mounting combinations making it suitable for new installations as well as retrofit applications. The power meter fits both in 4" round and DIN96 square cutouts. The transducer unit can be mounted on opposite side of the display, on any flat surface or onto a 35mm DIN rail.

The modularity and the upgrade path allow a low initial investment, but as well, to meet future needs. These features allow to build specific meter configurations as required.

CONFIGURATIONS

- 1) DIN 96x96 compact instrument
- 2) ANSI 4" instrument
- 3) ANSI 4" display + remote transducer
- 4) Transducer without display

Benefits

- The UPM310 provides hundreds of accurate True RMS metering values at low cost.
- It provides peak average current and power demand information. This data is essential to work out proper strategies aimed at avoiding uncontrolled power peaks and consequent penalties.
- Being ultra-compact with flexible mounting, the UPM310 is suitable for replacing conventional meters. It fits in ANSI 4" and DIN 96 cutout allowing retrofit to existing equipment.
- The UPM310 allow time and cost saving on mounting, compared to many individual single-function instruments.
- Via communication port it is possible to read and log on a PC all the readings and download the stored data.
- The recorded data allows to generate on a PC consumption profiles, logged values trends, event and alarm reporting, cost allocation and reports as well as to identify critical values.

Applications

- Switchboards, gensets, motor control centers, etc.
- Power monitoring & control systems
- Individual machine load monitoring
- Demand management
- Harmonics monitoring
- Remote metering and cost allocation

Main Features

Measurements

- Three-phase 3-wire or 4-wire unbalanced load operation
- True RMS metering provides accurate measurement even for distorted waveform
- Fully bi-directional, four-quadrant readings
- Volts, Amps, Power, PF, Frequency, Energy, Min/Max values, Demand and more
- Individual & total harmonic distortion for voltage and current up to the 31st order
- Direct measurement up to 600 (750)V_{AC}
- Programmable 1A / 5A current full scale.

Modularity

- Two slots for plug-in option boards
- The transducers version, the ANSI 4" display unit and the compact DIN 96 instrument allow various mounting combinations to fit the requirements of new installations as well as retrofit applications. The "Physical Configurations" page shows the mounting combinations

On-Board Memory

- 128k or 2MBytes non-volatile memory for data storage
- Programmable start/stop time of recordings
- Wraparound or Fill (FIFO/Stack) selectable recording mode
- Min/Avg/Max logging every 1, 5, 10, 15, 30, 60 minutes, programmable up to eight selectable parameters
- Total and daily energy consumption recording . Are stored the individual consumptions of more than 300 days
- Event, alarm and digital outputs ON/OFF recording

Communication

- Both RS232 and RS485 included in the basic unit. The selection is made by dip-switches
- Modbus protocol or standard ASCII protocol
- Communication speed programmable up to 57,600 bps
- Optional 10/100 Ethernet, Profibus or Lonbus interfaces

Inputs & Outputs

- Up to 6 digital outputs for energy pulsing or for alarm tripping. Two digital Optomos ML outputs are included in the basic unit.
- Up to 4 analog outputs 0-20 or 4-20 mA
- Optional four digital inputs for pulse counting

Other

- Real time waveform downloading via communication port. This function allows to represent graphically on the PC the three voltages and the three currents with 128 samples per cycle.
- On-board HTML Web Page server or direct communication through Ethernet / Internet network using Modbus or standard ASCII protocol
- Real Time Clock with battery backup

INSTANTANEOUS MEASUREMENTS		
PHASE VOLTAGE	$V_{L1-N} - V_{L2-N} - V_{L3-N}$ [V]	●
LINE VOLTAGE	$V_{L1-L2} - V_{L2-L3} - V_{L3-L1}$ [V]	●
SYSTEM VOLTAGE	V [V]	●
LINE CURRENT	$I_{L1} - I_{L2} - I_{L3} - I_N$ [A]	■
SYSTEM CURRENT	I [A]	■
POWER FACTOR	$PF_{L1} - PF_{L2} - PF_{L3}$	●
SYSTEM POWER FACTOR	PF	●
COSØ	$DPF_{L1} - DPF_{L2} - DPF_{L3}$	○
APPARENT POWER	$S_{L1} - S_{L2} - S_{L3}$ [VA]	■
SYSTEM APPARENT POWER	S [VA]	■
ACTIVE POWER	$P_{L1} - P_{L2} - P_{L3}$ [W]	■
SYSTEM ACTIVE POWER	P [W]	■
REACTIVE POWER	$Q_{L1} - Q_{L2} - Q_{L3}$ [var]	■
SYSTEM REACTIVE POWER	Q [var]	■
FREQUENCY	f [Hz]	●
DEMAND (AVERAGE VALUES)	$P_{AV} - S_{AV} - Q_{AV} - I_{AV}$	●
THERMAL CURRENT	$I_{L1} - I_{L2} - I_{L3}$ [A ² s]	□
VOLTAGE THD	$THD_{L1} - THD_{L2} - THD_{L3}$ [%]	○
CURRENT THD	$THD_{L1} - THD_{L2} - THD_{L3}$ [%]	○
FFT ANALYSIS 31 ST	$V_{L1-N} - V_{L2-N} - V_{L3-N} - I_{L1} - I_{L2} - I_{L3}$ [% , V , A]	○
UNBALANCE	V, I [%]	□
PHASE REVERSAL	123 / 132	●
REAL TIME CLOCK	Date, Time	●
STORED DATA		
SYSTEM ACTIVE ENERGY	[Wh]	■
SYSTEM APPARENT ENERGY	[VAh]	■
SYSTEM LAGGING REACTIVE ENERGY	[varh ind]	■
SYSTEM LEADING REACTIVE ENERGY	[varh cap]	■
MIN / MAX VALUES WITH TIME REFERENCE ⁽¹⁾	7xV, 5xI, f, 4xPF, 6xTHD	□
PEAK VALUES	$P_{AV} - S_{AV} - Q_{AV} - I_{AV}$	●
PROGRAMMABLE RECORDINGS		
DAILY CONSUMPTION (More than 300 days)	[Wh, VAh, varh]	■
ALARM / EVENT LOG	4 Set Points, Outputs ON/OFF, Instrument ON/OFF	□
MIN / AVG / MAX VALUES ⁽²⁾	[⁽²⁾]	●
● = Standard ■ = Bi-directional value □ = Extended Measurement ENH ○ = Optional		
(1) Time reference information (date and hour) is available only via serial port (2) Programmable every 1, 5, 10, 15, 30, 60 min - Maximum 8 measured parameters		

Specifications

Power supply

Rated voltage: 65 - 250 V_{AC} 50/60Hz or 90 - 250 V_{DC}
(19 - 60 V_{DC} - OPTION)
Consumption: 5VA max

Voltage inputs

Maximum measurable voltage: 600 (750)V_{AC} max L-L
Input impedance: >1.3 MΩ
Burden: max 0.15 VA per phase
Frequency: 45 - 65 Hz

Current inputs

Rated current (I_b): 1 / 5 A_{RMS} programmable
Min / max measurable current: 20 mA / 7 A_{RMS}
Maximum overload: 10A_{RMS} continuous - 100 A_{RMS} for 1 sec.
Input impedance: 0.02 Ω approximately
Burden: max 0,5 VA per phase
Insulation voltage: 150 V_{AC} max between phases

Typical accuracy

Voltage: ± 0.1% reading ± 0.03% full scale
Current: ± 0.1% reading ± 0.05% full scale
Active power: ± 0.5% reading ± 0.1% full scale (PF=1)
Power factor: 1% reading (0.5 inductive - 0.8 capacitive)
Active energy: 1% reading (0.5 inductive - 0.8 capacitive)
Frequency: ± 0.05% reading ± 2 digits from 45 to 65 Hz

Display and operating controls

Display: High brightness 13,8 mm LED display, three lines, 4 alphanumeric digits
Keypad: 4 push-buttons

Data memory

Type: On-Board non-volatile FLASH, 128kB or 2 MB

Communication port

Type: No.1 selectable RS232 or RS485, optoisolated
No.1 available for plug-in comm. boards
Baud Rate: 300 to 57600 bps

Real Time Clock

Type: with battery backup
Accuracy: ± 30 ppm

Digital outputs

Type: No.2 isolated Optomos (50V - 300mA_{AC-DC})

Environmental conditions

Operating temperature: from -15 °C to +60 °C
Storage temperature: from -30 °C to +75 °C
Relative humidity: 80% max. without condensation

Mechanical characteristics

Material: Metal enclosure
Protection degree: IP54 (front panel); IP20 (terminals)
Terminals: Pluggable terminal blocks
(Barrier terminal strips - OPTION)
Size / Weight: 96 x 96 x 130 (mm) DIN version 750 gr
110 x 110 x 40 (mm) ANSI Display 390 gr
90 x 90 x 130 (mm) Transducer 800 gr

Standards compliance

Safety: UL recognized under UL61010B-1and CAN/CSA-C22.2 No. 1010-1-92 File # E231725, 73/23/EEC, 93/68/EEC directives, EN61010-1 89/366/EEC directive and following modifications 93/31/EEC and 93/68/EEC, EN50081-2, EN50082-2, EN61326/A1
EMC:

TYPICAL WIRING DIAGRAMS

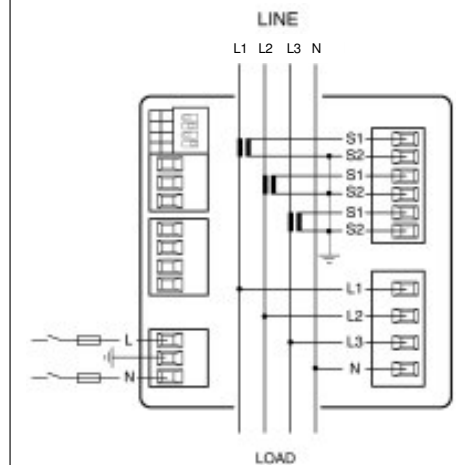

3-Phase 4-Wire up to 600V

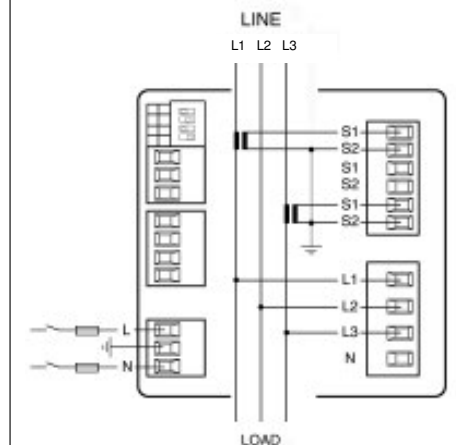

3-Phase 3-Wire above 600V

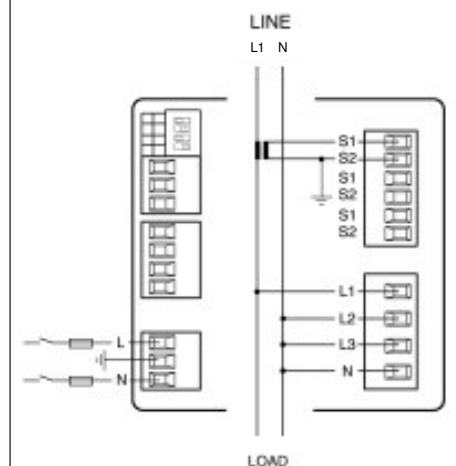

Single-Phase up to 400V

PHYSICAL CONFIGURATIONS

Compact DIN 96x96 instrument

Compact version according DIN 96 standard (92 x 92 mm cutout)

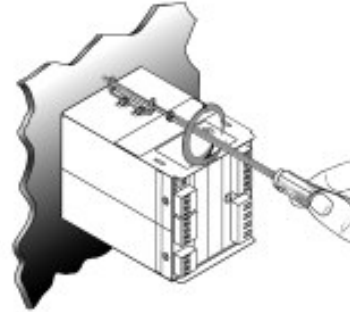
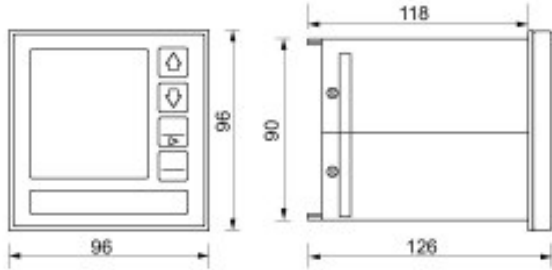

ANSI 4" instrument (display + transducer)

The drawings below show the transducer mounted on the backside of the ANSI 4" display.

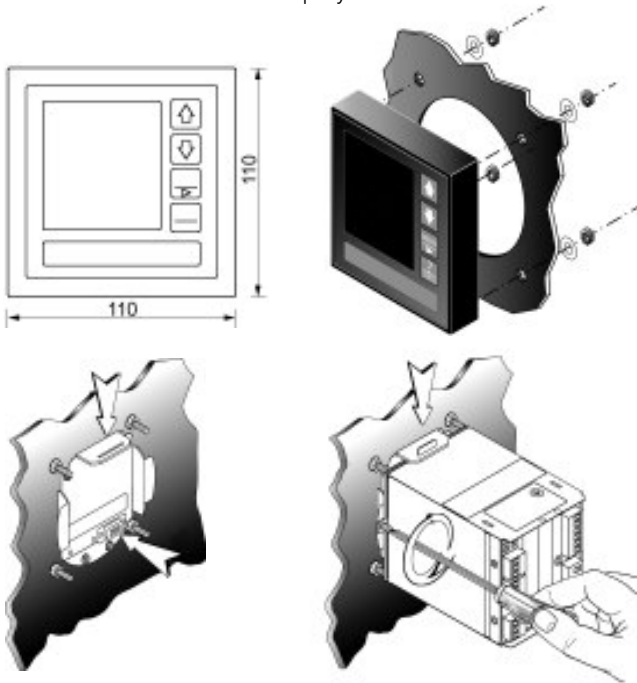

Transducer

The transducer can be mounted, using the adapter, on a flat surface or on a DIN Rail. It can be connected to the display by a 3m (~10 feet) provided cable.

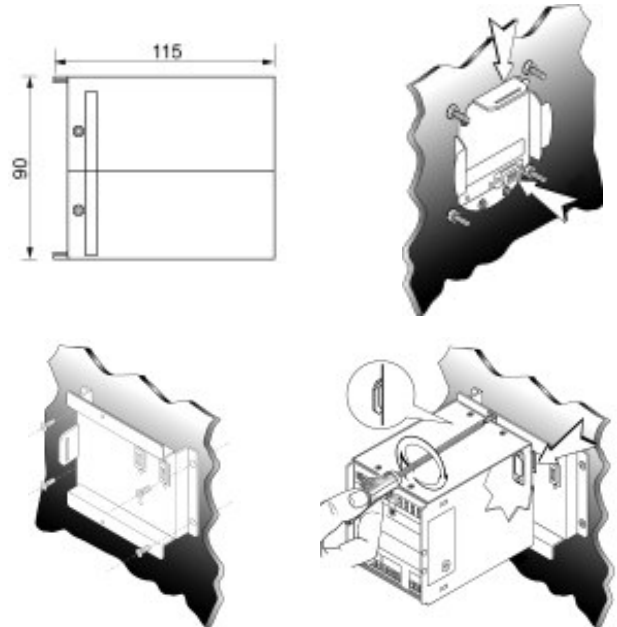

Rear connections - Standard pluggable terminals

The RS232 / RS485 programmable port and the two digital outputs are included in the basic configuration. Two slots are available for option boards.

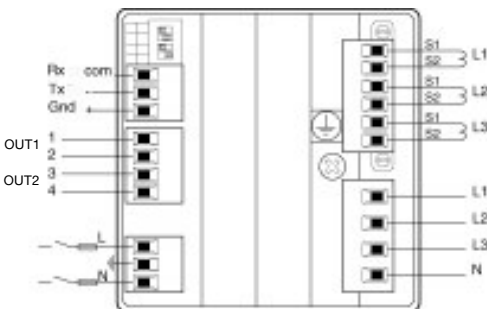

Rear connections - Barrier terminal strips (OPTION)

The RS232 / RS485 programmable port and the two digital outputs are included in the basic configuration. Two slots are available for option boards.

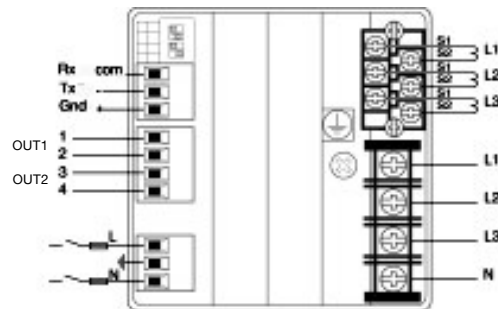

ORDERING INFORMATION																													
<div style="text-align: center; font-weight: bold; font-size: 1.2em; margin-bottom: 10px;">ALP A 5 X</div> <p>UPM310</p> <p>Series</p> <p>User's Manual Language D = German I = Italian U = English</p> <p>Communication Protocol B = ASCII Standard C = Modbus E = Ethernet board L = Lonbus board P = Profibus board</p> <p>Aux Power Supply A = 65 ÷ 250V_{AC} / 90 ÷ 250V_{DC} R = 19 ÷ 60V_{DC}</p> <p>Serial Port 5 = RS232/485 selectable by dip-switches (1)</p> <p>Memory 1 = 128 kBytes (1) 6 = 2 MBytes + Extended measurement ENH</p> <p>Firmware Options 2 = Basic version (1) 3 = Harmonics to 31st + DPF 4 = Enhanced package + Harmonics + DPF + 2MBytes</p> <p>Unused X = None</p>	<p>Physical Configuration</p> <p>STANDARD PLUGGABLE TERMINALS (EU) A = DIN 96x96 Instrument B = ANSI Display + Transducer C = ANSI Display + Transducer + Cable + mounting accessories E = Transducer + mounting accessories</p> <p>BARRIER TERMINAL STRIPS (USA) G = DIN 96x96 Instrument H = ANSI Display + Transducer I = ANSI Display + Transducer + Cable + mounting accessories K = Transducer + mounting accessories</p> <p>Inputs (2) X = None 4 = No.1 DI4-TR board - (No.4 digital inputs)</p> <p>Analog Outputs (2) X = None A = No.1 AO2-0420 board - (No.2 programmable analog outputs) R = No.2 AO2-0420 boards - (No.4 programmable analog outputs)</p> <p>Digital Outputs (2) 2 = Basic version with No.2 built-in optomos outputs (50V - 300mA_{AC-DC}) (1) 4 = No.1 DO2-ML board - (No.2 ML outputs) 6 = No.1 DO4-ML boards - (No.4 ML outputs) R = No.1 DO2-R board - (No.2 relay outputs) S = No.1 DO4-RML board - (No.2 relay outputs + No.2 ML outputs) V = No.1 DO2-MH board - (No.2 MH outputs) W = No.1 DO4-MH boards - (No.4 MH outputs)</p>																												
PLUG-IN BOARDS																													
<table border="1" style="width: 100%; border-collapse: collapse;"> <tr> <td style="padding: 2px;">D02-ML</td> <td style="padding: 2px;">No.2 Optomos Outputs (50V - 300mA_{AC-DC})</td> <td style="padding: 2px;">DI4-TR</td> <td style="padding: 2px;">No.4 Digital Inputs for Voltage-Free Contacts</td> </tr> <tr> <td style="padding: 2px;">D02-MH</td> <td style="padding: 2px;">No.2 Optomos Outputs (250V - 80mA_{AC-DC})</td> <td style="padding: 2px;">PROFI</td> <td style="padding: 2px;">Profibus DP Interface</td> </tr> <tr> <td style="padding: 2px;">D02-R</td> <td style="padding: 2px;">No.2 Relay Outputs (250V - 2A_{AC} resistive)</td> <td style="padding: 2px;">LON</td> <td style="padding: 2px;">Lonbus Interface</td> </tr> <tr> <td style="padding: 2px;">D04-ML</td> <td style="padding: 2px;">No.4 Optomos Outputs (50V - 300mA_{AC-DC})</td> <td style="padding: 2px;">ETH</td> <td style="padding: 2px;">10/100 Ethernet Interface</td> </tr> <tr> <td style="padding: 2px;">D04-MH</td> <td style="padding: 2px;">No.4 Optomos Outputs (250V - 80mA_{AC-DC})</td> <td></td> <td></td> </tr> <tr> <td style="padding: 2px;">D04-RML</td> <td style="padding: 2px;">No.2 Relay + No.2 Optomos (ML) Outputs</td> <td></td> <td></td> </tr> <tr> <td style="padding: 2px;">AO2-0420</td> <td style="padding: 2px;">No.2 0÷20 or 4÷20mA Analog Outputs</td> <td></td> <td></td> </tr> </table>	D02-ML	No.2 Optomos Outputs (50V - 300mA _{AC-DC})	DI4-TR	No.4 Digital Inputs for Voltage-Free Contacts	D02-MH	No.2 Optomos Outputs (250V - 80mA _{AC-DC})	PROFI	Profibus DP Interface	D02-R	No.2 Relay Outputs (250V - 2A _{AC} resistive)	LON	Lonbus Interface	D04-ML	No.4 Optomos Outputs (50V - 300mA _{AC-DC})	ETH	10/100 Ethernet Interface	D04-MH	No.4 Optomos Outputs (250V - 80mA _{AC-DC})			D04-RML	No.2 Relay + No.2 Optomos (ML) Outputs			AO2-0420	No.2 0÷20 or 4÷20mA Analog Outputs			<p>NOTES</p> <p>1) The basic instrument configuration includes:</p> <ul style="list-style-type: none"> • Power Supply 65 ÷ 250V_{AC} / 90 ÷ 250V_{DC} • No.2 Optomos outputs (50V - 300mA_{AC-DC}) • RS232 / 485 selectable by dip-switches • 128 kBytes data recording memory • Real Time Clock with battery backup <p>2) The basic instrument can be equipped with maximum 2 option boards.</p>
D02-ML	No.2 Optomos Outputs (50V - 300mA _{AC-DC})	DI4-TR	No.4 Digital Inputs for Voltage-Free Contacts																										
D02-MH	No.2 Optomos Outputs (250V - 80mA _{AC-DC})	PROFI	Profibus DP Interface																										
D02-R	No.2 Relay Outputs (250V - 2A _{AC} resistive)	LON	Lonbus Interface																										
D04-ML	No.4 Optomos Outputs (50V - 300mA _{AC-DC})	ETH	10/100 Ethernet Interface																										
D04-MH	No.4 Optomos Outputs (250V - 80mA _{AC-DC})																												
D04-RML	No.2 Relay + No.2 Optomos (ML) Outputs																												
AO2-0420	No.2 0÷20 or 4÷20mA Analog Outputs																												

Subject to change without notice



**ENERGY MEASUREMENT
AND CONTROL**

ALGODUE ELETTRONICA s.r.l.
 Via Passerina, 3/A
 28010 FONTANETO D'AGOGNA
 (NO) ITALY

Tel: +39 0322 89864 - 89307
 Fax: +39 0322 89871
 E-mail: info@algodue.com
 Website: www.algodue.com

