

UPM3100

DIN 144x144 LCD Quality Power Meter

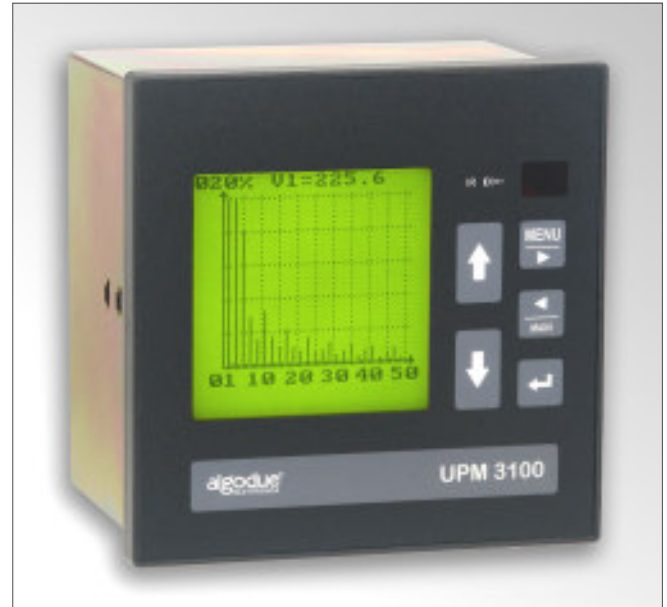

- Highly Soffisticated Power Meter Providing Advanced Functionality Features
- UL Listed Under UL61010B-1 and CAN/CSA-C22.2 No.1010.1-92, File #E231725
- Large Graphic LCD Display with Excellent Visibility
- Up to Four Plug-In Options
- Infrared Communication Port
- THD Even, Odd and Individual FFT Harmonic Analysis up to 50th Order
- Power and Current Demand Calculation
- On-Board Memory up to 2MBytes
- Up to 10 programmable recordings with different start and stop time
- Event and Alarm Recording, Sags and Swells Detection, Waveform Capture, Waveform Display, Phasor Diagrams, Historical Trending, Time-of-Use and more....



General Description

The UPM3100 is a multifunction metering device with advanced functionality features, suitable for electrical parameters measurement and power quality analysis.

The UPM3100 is able to store the measured values according to a programmable rate and the events when they occur.

The UPM3100 main feature is its flexibility: in the rear side of the instrument it is possible to plug in up to four add-on option boards. The modularity and the upgrade path allow a low initial investment but as well to meet future needs. These features allow to build specific meter configurations as required.

The basic unit includes RS232 / RS485 switchable communication port and one front panel infrared port.

The UPM3100 provides accurate True RMS values on graphic LCD display, or via communication port. Four or more parameters displayed simultaneously give the complete situation of the electrical line at first sight.

It performs clear graphical functions such as: waveforms of voltage and current, harmonic spectrum, phasor diagrams, trends of measured values and consumption profiles.

The backlighted LCD display is highly efficient therefore it guarantees perfect visibility in all light conditions.

A simple menu structure makes the instrument easy-to-use and allows a quick check of the instrument set-up and memory status. Five languages can be selected easily: English, German, Italian, French and Spanish.

Benefits

- The UPM3100 is suitable for low, medium and high voltage measurement. It can be connected directly up to 600 (750)V_{AC} L-L or through PTs for higher voltage.
- It provides peak average current and power demand information. This data is essential to work out proper strategies aimed at avoiding uncontrolled power peaks and consequent penalties.
- The 2MBytes data memory allows a long-term data recording without connection to a computer for downloading.
- Via communication port it is possible to read and log on a PC all the readings and download the stored data.
- The recorded data allows to generate on a PC consumption profiles, logged values trends, event and alarm reporting, cost allocation and reports as well as to identify critical values.

Applications

- Switchboards, gensets, motor control centers, etc.
- Power monitoring & control systems
- Individual machine load monitoring
- Power demand analysis and management
- Harmonics monitoring
- Remote metering and cost allocation
- Motor inrush current studies

Main Features

Measurements

- Three-phase 3-wire or 4-wire unbalanced load operation, bi-phase and single-phase. There are approximately ten ways of connecting UPM3100 as showed on page 5.
- Direct measurement up to 600 (750)V_{AC}
- Programmable 1A / 5A current full scale
- Fully bi-directional, four-quadrant readings. 10 energy counters are available, the apparent power/energy is splitted in four counters: import lagging, import leading, export lagging, export leading
- Volts, Amps, Power, PF, Frequency, Energy, Min/Max values, Demand, Harmonics, etc. The full version instrument provides more than 600 measured/calculated parameters and shows on the LCD more than 30 graphical pages

Power Quality

- Individual & total harmonic distortion for voltage and current up to the 50th order. The harmonic content is represented like even, odd and total
- CPU2 option - the co-processor board performs the simultaneous high-resolution sampling of voltage and current, allowing the cycle-by-cycle power analysis for 50/60 Hz lines. The CPU2 board supports different application like: VDROD, VMAX, WCAP... (see below). The instrument with CPU2 board performs at the same time the wattmeter functions, the harmonic analysis, the basic recording function and the selected cycle-by-cycle power analysis function.
- VDROD option - sags & swells detection on L-N voltages with half cycle resolution (10ms @ 50Hz). Pre- and post-trigger logging (100+100 half cycles RMS values). The detected events are recorded and a relay output can be activated when a voltage anomaly occurs. This data is viewed on the PC according EN50160 standard.
- VMAX option - two functions are selectable: VDROD (previous paragraph) and Min/Avg/Max values calculation and recording with one cycle resolution (20ms @ 50Hz). This function allows to record up to 10 parameters selected among voltage, current, power, PF and frequency. The data is viewed on the PC according EN50160 standard.
- WCAP option - advanced waveform capture function on currents and L-N voltages. The instrument can store up to 10 + 200 waveforms before and after a threshold overcome, with a resolution from 8 to 32 samples (depending on the number of waveforms). The WCAP option includes a second selectable function: Min/Avg/Max values calculation and recording (see previous paragraph)

Recordings

- 2MB non-volatile memory for data storage
- Up to 10 programmable recordings with different start and stop time. Different type of recordings can be chosen:

- import/export active, reactive and apparent power demand with programmable average time. The average period can be synchronized by a digital input
- instantaneous read values selected between the main parameters. The recording interval time is programmable between 1 and 9999 seconds
- instantaneous min/max values measured during the recording interval time. The recording interval time is programmable between 1 and 9999 minutes
- voltage and current harmonic values measured during the recording interval time. The recording interval time is programmable from 1 to 60 minutes
- Time-of-Use (TOU) programmable data recording. The TOU function stores the energy consumption in different registers according the programmed time-scheme. A group of 120 registers give the situation of the previous and present day, and of the previous and present month. This feature is designed to fit different tariff structures. It's possible to program up to 10 daily tariff schedules containing up to 3 tariffs and 8 tariff changes. Each schedule can be assigned to the days of the week and months as requested. Up to 20 holidays can be assigned to the lowest tariff. A diagnostic algorithm checks and notifies any setup overlapping.
- Event, alarm and digital outputs ON/OFF recording. The instrument records the status change of 8 programmable set points, the digital outputs ON/OFF and the instrument supply ON/OFF. All the events are integrated by date and time reference
- The CPU2 option includes 1MBytes non-volatile data memory. Depending on the CPU2 configuration the following information (already described in the "Power Quality" paragraph) can be recorded:
 - sags and swells events (VDROD option). The occurring dips and overvoltage over a programmable threshold are detected and the instrument records the date and time of the event, the length and the RMS value of 100 + 100 half-cycles before and after the event
 - min / avg / max values of the main measured parameters with continuous sampling and 1 cycle minimum resolution for RMS calculation. The resolution is programmable between 1 and 99 cycles to simulate the recorder response time as needed. The programmable average time defines the time interval between recordings
 - more than 200 waveforms when a programmable threshold is overcome (WCAP option). The instrument records up to 10 + 200 waves before and after the trigger, with the time reference. The resolution is programmable from 8 to 32 samples / cycle.

Modularity

- Four slots for plug-in options boards

Communication

- Both RS232 and RS485 included in the basic unit. The selection is made by dip-switches
- Modbus protocol or standard ASCII protocol
- Communication speed programmable up to 57.600 bps
- Optional 10/100 Ethernet, Profibus or Lonbus interfaces
- On-board HTML Web Page server or direct communication through Ethernet / Internet network using Modbus or standard ASCII protocol

Inputs & Outputs

- Up to 6 digital outputs for energy pulsing or for alarm tripping. Two digital Optomos ML outputs are included in the basic unit.

- Up to 4 analog outputs 0-20 or 4-20 mA
- Optional four digital inputs for pulse counting. A multiplier is programmable for each input in order to store the real quantities, as well different measurement units are selectable (kWh, kVAh, kvarh, m³, etc.)
- One of the digital inputs can be programmed as demand period synchronization input

Other

- Real Time Clock with battery backup
- Calculation of capacitor bank value for PF compensation
- Five alpha-numeric characters password to avoid unauthorized setup access

WCAP - Waveform capture examples

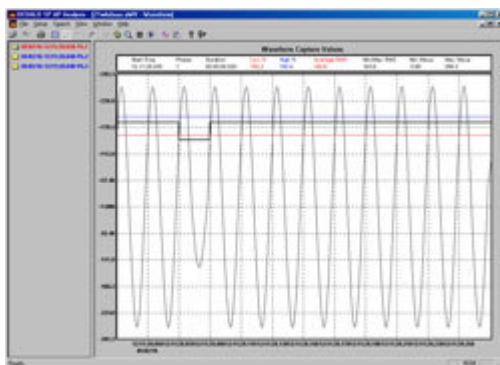

Voltage drop - The trigger is on voltage RMS value, the resolution is 1 cycle. Are represented 2+10 waves before and after the trigger, the sampling is 32 samples / cycle.

Current load variation - The trigger is on current RMS value, the resolution is 1 cycle. Are represented 5+30 waves before and after the trigger, the sampling is 8 samples / cycle.

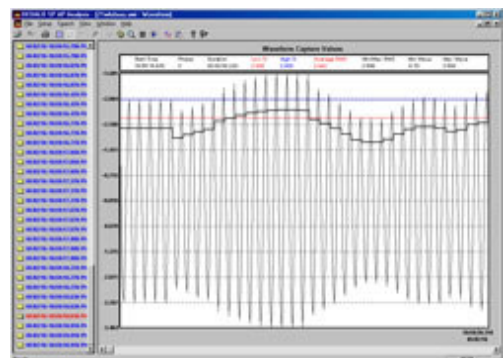

INSTANTANEOUS MEASUREMENTS	
PHASE VOLTAGE	$V_{L1-N} - V_{L2-N} - V_{L3-N}$ [V] ●
LINE VOLTAGE	$V_{L1-L2} - V_{L2-L3} - V_{L3-L1}$ [V] ●
SYSTEM VOLTAGE	V [V] ●
LINE CURRENT	$I_{L1} - I_{L2} - I_{L3} - I_N$ [A] ■
SYSTEM CURRENT	I [A] ■
POWERFACTOR	$PF_{L1} - PF_{L2} - PF_{L3}$ ●
SYSTEM POWER FACTOR	PF ●
COSØ	$DPF_{L1} - DPF_{L2} - DPF_{L3}$ ●
APPARENT POWER	$S_{L1} - S_{L2} - S_{L3}$ [VA] ■
SYSTEM APPARENT POWER	S [VA] ■
ACTIVE POWER	$P_{L1} - P_{L2} - P_{L3}$ [W] ■
SYSTEM ACTIVE POWER	P [W] ■
REACTIVE POWER	$Q_{L1} - Q_{L2} - Q_{L3}$ [var] ■
SYSTEM REACTIVE POWER	Q [var] ■
FREQUENCY	f [Hz] ●
DEMAND (BI-DIRECTIONAL)	$P_{AV} - Q_{AV} - S_{AV} - I_{AV} - I_{L1AV} - I_{L2AV} - I_{L3AV} - I_{NAV}$ ●
THERMAL CURRENT	$I_{L1} - I_{L2} - I_{L3}$ [A ² s] □
K-FACTOR & FACTOR K (US & EU)	[K] □
VOLTAGE THD (Total, Even, Odd)	$THD_{L1} - THD_{L2} - THD_{L3}$ [%] ●
CURRENT THD (Total, Even, Odd)	$THD_{L1} - THD_{L2} - THD_{L3}$ [%] ●
FFT ANALYSIS 50 th	$V_{L1-N} - V_{L2-N} - V_{L3-N} - I_{L1} - I_{L2} - I_{L3} - I_N$ [% , V, A] ●
FFT ANALYSIS 50 th + VOLTAGE AND CURRENT THD (Total)	I_N [% , V, A] □
UNBALANCE	V, I [%] □
PHASE REVERSAL	123 / 132 ●
REAL TIME CLOCK	Date, Time ●

STORED DATA	
SYSTEM ACTIVE ENERGY	[Wh] ■
SYSTEM LAGGING APPARENT ENERGY	[VAh] ■
SYSTEM LEADING APPARENT ENERGY	[VAh] ■
SYSTEM LAGGING REACTIVE ENERGY	[varh ind] ■
SYSTEM LEADING REACTIVE ENERGY	[varh cap] ■
MIN / MAX VALUES WITH TIME REFERENCE	[V, A, W, VA, var, PF] ■
PEAK VALUES WITH TIME REF.	$P_{AV} - Q_{AV} - S_{AV} - I_{AV} - I_{L1AV} - I_{L2AV} - I_{L3AV} - I_{NAV}$ ■
PROGRAMMABLE RECORDINGS	
POWER DEMAND (BI-DIRECTIONAL)	$P_{AV} - Q_{AV} - S_{AV}$ ●
INSTANTANEOUS VALUES	[V, A, W, VA, var, PF, Hz, THD] ●
INSTANTANEOUS MIN/MAX VALUES	[V, A, W, VA, var, PF] ●
HARMONICS	[V, A - up to 50 th] ●
EVENT CAPTURE	8 threshold, outputs, aux power supply [ON/OFF] □
SAGS AND SWELLS	[V - 10ms resolution] ○
MIN / AVG / MAX VALUES(1)	[V, I, P, Q, S, f(1) - 20ms resolution] ○
WAVEFORM CAPTURE	$V_{L1-N} - V_{L2-N} - V_{L3-N}$ or $I_{L1} - I_{L2} - I_{L3}$ ○
ADVANCED FEATURES	
TIME OF USE (TARIFF REGISTERS)	[Wh, VAh, varh] ■
CALCULATION OF PF COMPENSATION	Capacitor bank [kvar] ●
DIGITAL INPUTS COUNTERS	[Wh, VAh, varh, m ³ , litres, etc.] ○

● = Standard ■ = Bi-directional value
○ = Optional □ = Extended Measurement Package

(1) Programmable every 1, 5, 10, 15, 30, 60 min - Maximum 10 parameters selected among voltage, current, power, PF, frequency

Programmable Recordings Detail				(1) It is possible to set 10 different start/stop corresponding to 10 different recordings
				(2) The measurements are carried out with continuous sampling
	TYPE OF RECORDED DATA	RECORDING INTERVAL	START/STOP RECORDING (1)	RECORDED PARAMETERS
BASIC VERSION	POWER DEMAND	1, 5, 10, 15, 30, 60 minutes	PROGRAMMABLE	Active, Reactive Inductive, Reactive Capacitive, Apparent (IMPORT)
	MINIMUM / MAXIMUM values	from 1 to 9999 minutes	PROGRAMMABLE	V - $V_{L1-N} - V_{L2-N} - V_{L3-N}$ - I - $I_{L1} - I_{L2} - I_{L3}$ - P - S - Q - PF - Demand values
	INSTANTANEOUS VALUES (Snapshots)	from 1 to 9999 seconds	PROGRAMMABLE	$V - V_{L1-N} - V_{L2-N} - V_{L3-N} - V_{L1-L2} - V_{L2-L3} - V_{L3-L1} - I - I_{L1} - I_{L2} - I_{L3} - I_N$ PF - $PF_{L1} - PF_{L2} - PF_{L3} - CosØ - CosØ_{L1} - CosØ_{L2} - CosØ_{L3} - S - S_{L1} - S_{L2} - S_{L3}$ P - $P_{L1} - P_{L2} - P_{L3} - Q - Q_{L1} - Q_{L2} - Q_{L3} - F - THD V - THD I - P_{AV} - Q_{AV} - S_{AV}$
	HARMONICS	1, 5, 10, 15, 30, 60 minutes	PROGRAMMABLE	$V_{L1-N} - V_{L2-N} - V_{L3-N} - I_{L1} - I_{L2} - I_{L3} - (I_N \square)$
OPTIONS	SAGS AND SWELLS 10ms - VDROD (2)	When event occurs	CONTINUOUS	$V_{L1-N} - V_{L2-N} - V_{L3-N}$
	MIN / AVG / MAX values 20ms - VMAX (2)	from 1 to 999 seconds	PROGRAMMABLE	Max 10 values selected among voltage, current, power, frequency
	WAVEFORM CAPTURE 20ms - WCAP (2)	When event occurs	CONTINUOUS	$V_{L1-N} - V_{L2-N} - V_{L3-N}$ or $I_{L1} - I_{L2} - I_{L3}$

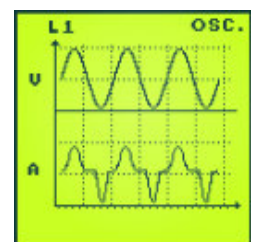
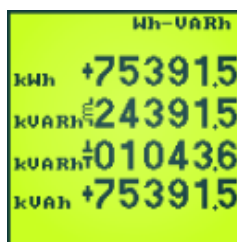

Specifications

Power supply

Rated voltage: 65 - 250 Vac 50/60Hz or 90 - 250 Vdc
(19 - 60 Vdc - option)

Consumption: 5VA max

Voltage inputs

Maximum measurable voltage: 600 (750)V_{AC} max L-L

Input impedance: >1.3 MΩ

Burden: max 0.15 VA per phase

Frequency: 45 - 65 Hz

Current inputs

Rated current (I_b): 1 / 5 A_{RM}s programmable

Min / max measurable current: 20 mA / 7 A_{RM}s

Maximum overload: 10A_{RM}s continuous - 100 A_{RM}s for 1 sec.

Input impedance: 0.02 Ω approximately

Burden: max 0,5 VA per phase

Insulation voltage: 150 V_{AC} max between phases

Typical accuracy

Voltage: ± 0.1% reading ± 0.03% full scale

Current: ± 0.1% reading ± 0.05% full scale

Active power: ± 0.5% reading ± 0.1% full scale (PF=1)

Power factor: 1% reading (0.5 inductive - 0.8 capacitive)

Active energy: 1% reading (0.5 inductive - 0.8 capacitive)

Frequency: ± 0.05% reading ± 1 digits from 45 to 65 Hz

Display and operating controls

Display: Backlighted graphic LCD display
128 x 128 dots

Keypad: 5 push-buttons

Data memory

Type: On-Board non-volatile FLASH, 2 MBytes

Communication port

Type: No.1 selectable RS232 or RS485, optoisolated
No.1 infrared port on the front panel

Baud Rate: 300 to 57600 bps

Real Time Clock

Type: with battery backup

Accuracy: ± 30 ppm

Digital outputs

Type: No.2 isolated Optomos (50V - 300mA_{AC-DC})

Environmental conditions

Operating temperature: from -15 °C to +60 °C

Storage temperature: from -25 °C to +75 °C

Relative humidity: 80% max. without condensation

Mechanical characteristics

Material: Metal enclosure

Protection degree: IP54 (front panel); IP20 (terminals)

Terminals: Pluggable terminal blocks
(Barrier terminal strips - OPTION)

Size / Weight: 144 x 144 x 110 mm 900 gr

Standards compliance

Safety: UL recognized under UL61010B-1 and CAN/
CSA-C22.2 No. 1010.1-92, File #E231725,
73/23/EEC, 93/68/EEC directives, EN61010.1
89/366/EEC directive and following
modifications 93/31/EEC and 93/68/EEC,
EN50081-2, EN50082-2, EN61326/A1

EMC:

PLUG-IN BOARDS

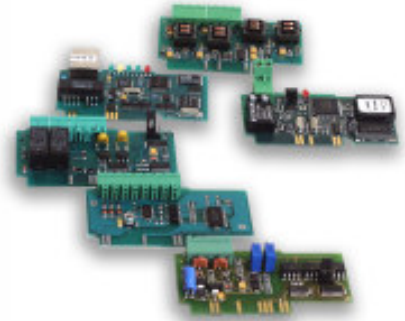

The UPM3100 has in the rear side 4 slots for plug-in boards. They allow to add useful I/O functions to complete the measuring function of the meter also after purchase.

DO2 / DO4 - Digital outputs

The digital outputs can detect when a threshold is overcome or can be used for energy pulse emission.

Number of channels: 2 / 4

ML type: 50V - 300mA_{AC-DC} (Optomos)

MH type: 250V - 80mA_{AC-DC} (Optomos)

RL type: 250V - 5A resistive (Relay)

AO2 - Analog outputs

The analog outputs can be programmed as 0÷20 mA or 4÷20 mA and can be used in order to transmit a signal to an external device.

Number of channels: 2

Type: active output with no need of external power supply

Load: 300 Ω max.

Resolution: 12 bits

DI4 - Digital inputs

The digital inputs can be used for the acquisition of energy pulses. The inputs have no need for an external power supply. The value of the pulse is programmable, allowing to count other values than energy.

Number of channels: 4

Type: isolated for voltage-free contact

Max frequency: 10Hz

Communication boards

The communication boards ensure the flexibility to interface other devices.

PROFI: Profibus DP-slave interface

LON: Lonbus Echelon FTT-10 interface

ETH: 10/100 Base-T Ethernet interface

TCOM: No.2 programmable RS232/485 ports

Wiring diagram examples

The UPM3100 offers total connection versatility for measuring inputs. There are approximately ten ways of connecting UPM3100, all of them programmable from the menu, thus allowing measurement of single-, bi- and three-phase systems.

The UPM3100 wiring diagrams are the results of the on-field experience, focused sometime to simplify the connection for a fast check on the power system. Beside are shown some examples.

Pict.1 - 3-Phase 4-Wire 3-CT

Standard connection for unbalanced loading condition.

Pict.2 - 3-Phase 3-Wire 2-CT

Aron connection for balanced loading condition. Two CTs only are used.

Pict.3 - 3-Phase 3-Wire 1-V

Simplified wiring diagram for unbalanced loads with only one voltage connection. The measuring error is proportional to the voltage unbalance. Useful for a fast check of the consumption.

Pict.4 - 3-Phase 3-Wire 1-CT

Simplified wiring diagram for balanced loads with only one current connection. The measuring error is proportional to the current unbalance. Useful for a fast check of the consumption and time /cost saving.

Pict.5 - Single Phase 3-Wire (Bi-Phase)

Single phase three wire diagram (bi-phase) with centered tapped neutral.

Pict.6 - Single Phase

Single phase wiring diagram.

The wiring diagrams show the voltage connections up to 600(750)V_{AC} L-L. Above this value the use of voltage transformers is necessary. The PT value is programmable.

NOTE: The number of displayed parameters depends on the selected wiring diagram.

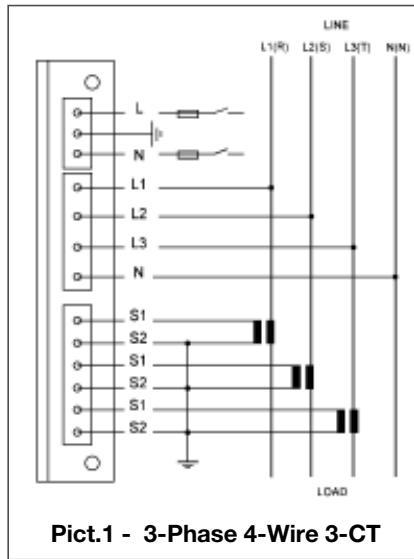

Pict.1 - 3-Phase 4-Wire 3-CT

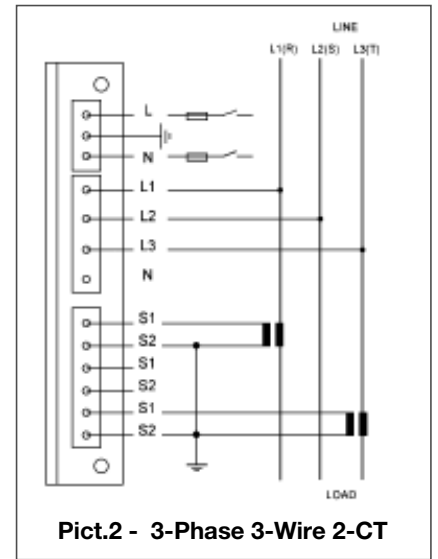

Pict.2 - 3-Phase 3-Wire 2-CT

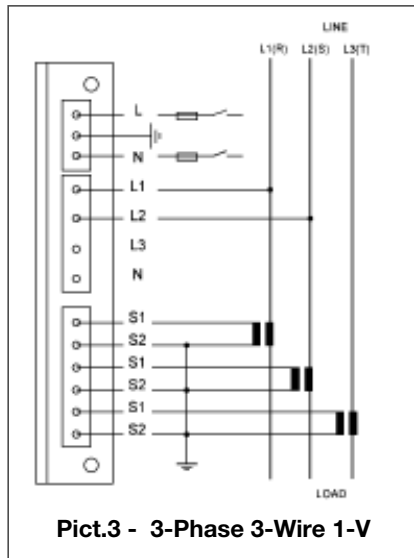

Pict.3 - 3-Phase 3-Wire 1-V

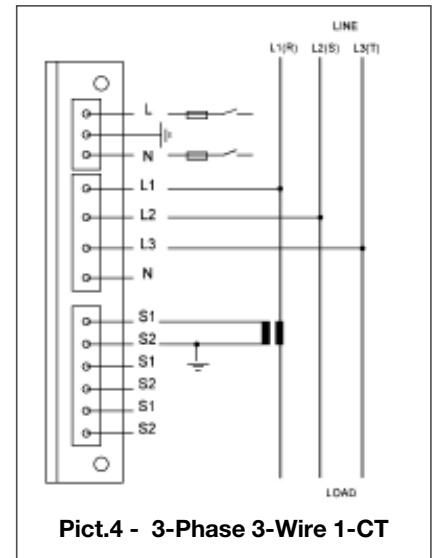

Pict.4 - 3-Phase 3-Wire 1-CT

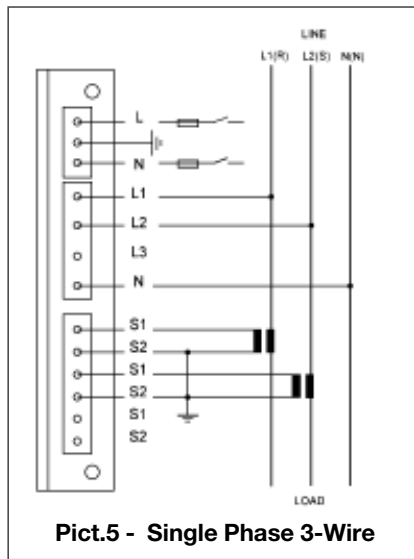

Pict.5 - Single Phase 3-Wire

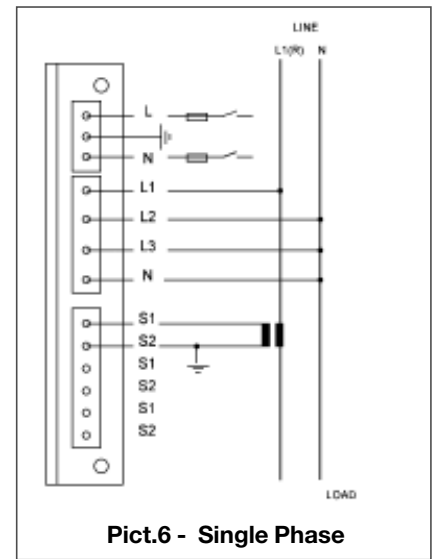

Pict.6 - Single Phase

DEDALO Communication Software

- For Microsoft Windows environments
- User-friendly
- Single point and network version
- Real-time data viewing and trending
- Quick instruments setup
- Up to 5 data logging files

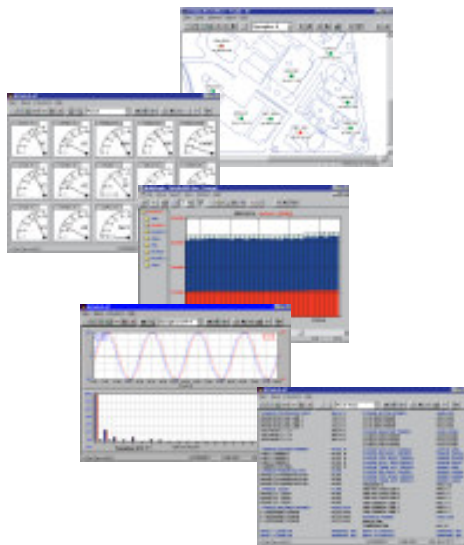

DEDALO software enables power meters to be connected to a PC. It allows to download, to display, to collect and analyse all electrical parameters.

It is also an easy and fast tool for direct or remote connection. It allows to connect to the meters by serial communication port (RS232 or RS485) or by external devices such as telephone line or Ethernet/Internet. This remote monitoring function allows to carry out all the functions from instrument setup to data monitoring or downloading.

The DEDALO software is available in two different versions:

- DEDALO SP: software for single meter connection.
- DEDALO NET: software version for a meter network up to 512 instruments. It is available as workstation package or for multiple user access (LAN version).

Main Features

DEDALO software performs the following main functions:

- Real-time Data Viewing and trending
- Instrument recordings download
- Quick Instrument Setup
- Alarms & Limits
- Up to 5 data logging files & Printouts
- Export Data File

Both the software basic versions can grow by additional functions as the requirements change.

Dimensions and panel cutout - mm

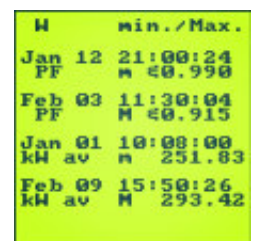
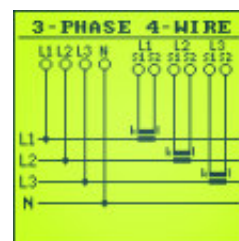
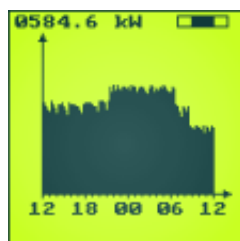
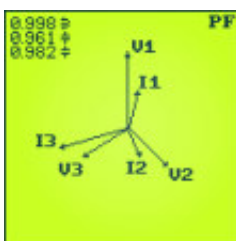
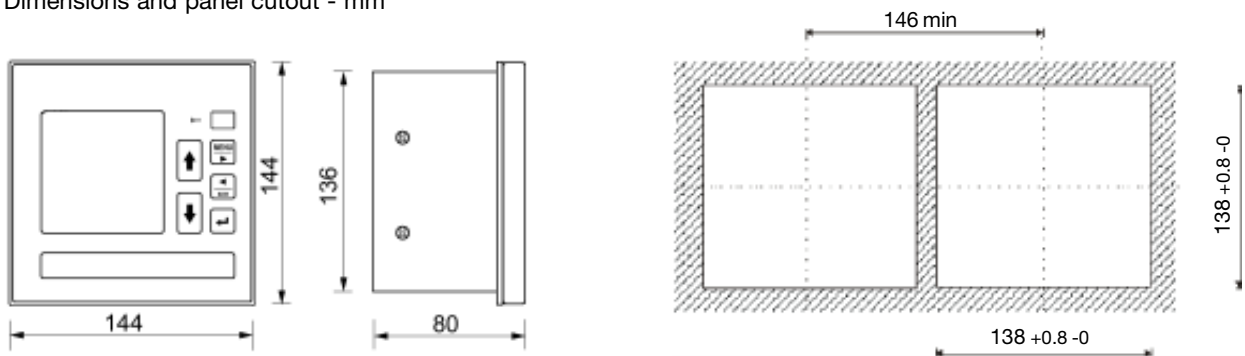

ORDERING INFORMATION																										
<div style="border: 1px solid black; padding: 5px; margin-bottom: 10px;"> <table style="width: 100%; text-align: center; border-collapse: collapse;"> <tr> <td style="border: 1px solid black; padding: 2px 10px;">ALZ</td> <td style="border: 1px solid black; padding: 2px 10px;">A</td> <td style="border: 1px solid black; width: 20px; height: 20px;"></td> <td style="border: 1px solid black; width: 20px; height: 20px;"></td> <td style="border: 1px solid black; width: 20px; height: 20px;"></td> <td style="border: 1px solid black; width: 20px; height: 20px;"></td> <td style="border: 1px solid black; padding: 2px 10px;">6</td> <td style="border: 1px solid black; width: 20px; height: 20px;"></td> <td style="border: 1px solid black; width: 20px; height: 20px;"></td> <td style="border: 1px solid black; width: 20px; height: 20px;"></td> <td style="border: 1px solid black; width: 20px; height: 20px;"></td> <td style="border: 1px solid black; width: 20px; height: 20px;"></td> </tr> </table> </div> <p>UPM3100</p> <p>Series</p> <p>User's Manual Language D = German I = Italian U = English</p> <p>Communication Protocol B = ASCII Standard C = Modbus E = Ethernet board (2) L = Lonbus board (2) P = Profibus board (2)</p> <p>Aux Power Supply A = 65 ÷ 250V_{AC} / 90 ÷ 250V_{DC} R = 19 ÷ 60V_{DC}</p> <p>Serial Port 5 = Selectable RS232/485 + infrared port (1) 2 = As above with RS232 pre-programmed 3 = Communication port for external printer LPR40 + infrared port (5) 4 = Two programmable RS232/485 ports (No.1 TCOM board) (2) 6 = Selectable RS232/485 + front panel RS232 instead of infrared port</p> <p>Memory 6 = 2MBytes</p> <p>Firmware Options 3 = Basic version (1) 4 = ENH - Extended measurement package</p>	ALZ	A					6						<p>Physical Configuration A = Standard pluggable terminals (EU) G = Barrier terminal strips (USA)</p> <p>Inputs (2) X = None 4 = No.1 DI4-TR board - (No.4 digital inputs)</p> <p>Analog Outputs (2) X = None 2 = No.1 AO2-0420 board - (No.2 programmable analog outputs) 4 = No.2 AO2-0420 boards - (No.4 programmable analog outputs) 8 = No.1 EBUS board for external EM80 device (No.8 analog outputs)</p> <p>Digital Outputs (2) (3) 2 = Basic version with No.2 built-in optomos outputs (50V - 300mA_{AC-DC}) (1) 4 = No.1 DO2-ML board - (No.2 ML outputs) 6 = No.1 DO4-ML boards - (No.4 ML outputs) R = No.1 DO2-R board - (No.2 relay outputs) S = No.1 DO4-RML board - (No.2 relay outputs + No.2 ML outputs) V = No.1 DO2-MH board - (No.2 MH outputs) W = No.1 DO4-MH boards - (No.4 MH outputs)</p> <p>Special Functions X = None 2 = VDROD - Sags and swells detection (4) 3 = VMAX - MIN/AVG/MAX cycle-by-cycle recording + VDROD (4) 4 = WCAP - Waveform capture + MIN/AVG/MAX cycle-by-cycle recording (4)</p>													
ALZ	A					6																				
PLUG-IN BOARDS																										
<table style="width: 100%; border-collapse: collapse;"> <tr> <td style="border-right: 1px solid black; padding: 2px;">DO2-ML</td> <td style="padding: 2px;">No.2 Optomos Outputs (50V - 300mA_{AC-DC})</td> </tr> <tr> <td style="border-right: 1px solid black; padding: 2px;">DO2-MH</td> <td style="padding: 2px;">No.2 Optomos Outputs (250V - 80mA_{AC-DC})</td> </tr> <tr> <td style="border-right: 1px solid black; padding: 2px;">DO2-R</td> <td style="padding: 2px;">No.2 Relay Outputs (250V - 2A_{AC} resistive)</td> </tr> <tr> <td style="border-right: 1px solid black; padding: 2px;">DO4-ML</td> <td style="padding: 2px;">No.4 Optomos Outputs (50V - 300mA_{AC-DC})</td> </tr> <tr> <td style="border-right: 1px solid black; padding: 2px;">DO4-MH</td> <td style="padding: 2px;">No.4 Optomos Outputs (250V - 80mA_{AC-DC})</td> </tr> <tr> <td style="border-right: 1px solid black; padding: 2px;">DO4-RML</td> <td style="padding: 2px;">No.2 Relay + No.2 Optomos (ML) Outputs</td> </tr> <tr> <td style="border-right: 1px solid black; padding: 2px;">AO2-0420</td> <td style="padding: 2px;">No.2 0÷20 or 4÷20mA Analog Outputs</td> </tr> <tr> <td style="border-right: 1px solid black; padding: 2px;">DI4-TR</td> <td style="padding: 2px;">No.4 Digital Inputs for Voltage-Free Contacts</td> </tr> <tr> <td style="border-right: 1px solid black; padding: 2px;">TCOM</td> <td style="padding: 2px;">No.2 programmable RS232/485 ports</td> </tr> <tr> <td style="border-right: 1px solid black; padding: 2px;">PROFI</td> <td style="padding: 2px;">Profibus DP Interface</td> </tr> </table>	DO2-ML	No.2 Optomos Outputs (50V - 300mA _{AC-DC})	DO2-MH	No.2 Optomos Outputs (250V - 80mA _{AC-DC})	DO2-R	No.2 Relay Outputs (250V - 2A _{AC} resistive)	DO4-ML	No.4 Optomos Outputs (50V - 300mA _{AC-DC})	DO4-MH	No.4 Optomos Outputs (250V - 80mA _{AC-DC})	DO4-RML	No.2 Relay + No.2 Optomos (ML) Outputs	AO2-0420	No.2 0÷20 or 4÷20mA Analog Outputs	DI4-TR	No.4 Digital Inputs for Voltage-Free Contacts	TCOM	No.2 programmable RS232/485 ports	PROFI	Profibus DP Interface	<table style="width: 100%; border-collapse: collapse;"> <tr> <td style="border-right: 1px solid black; padding: 2px;">LON</td> <td style="padding: 2px;">Lonbus Interface</td> </tr> <tr> <td style="border-right: 1px solid black; padding: 2px;">ETH</td> <td style="padding: 2px;">10/100 Ethernet Interface</td> </tr> </table> <p>NOTES (1) The basic instrument configuration includes:</p> <ul style="list-style-type: none"> • Power Supply 65 ÷ 250V_{AC} / 90 ÷ 250V_{DC} • No.2 Optomos Outputs (50V - 300mA_{AC-DC}) • RS232 / 485 selectable by dip-switches + infrared port • 2 MBytes data recording memory • Real Time Clock with battery backup 	LON	Lonbus Interface	ETH	10/100 Ethernet Interface	<p>(2) The basic instrument can be equipped with maximum 4 option boards.</p> <p>(3) The instrument can support maximum 6 digital outputs (included the two built-in)</p> <p>(4) Requires CPU2 option (co-processor board). It will be included by default</p> <p>(5) Available only for instrument without CPU2 (VDROD/VMAX/WCAP)</p>
DO2-ML	No.2 Optomos Outputs (50V - 300mA _{AC-DC})																									
DO2-MH	No.2 Optomos Outputs (250V - 80mA _{AC-DC})																									
DO2-R	No.2 Relay Outputs (250V - 2A _{AC} resistive)																									
DO4-ML	No.4 Optomos Outputs (50V - 300mA _{AC-DC})																									
DO4-MH	No.4 Optomos Outputs (250V - 80mA _{AC-DC})																									
DO4-RML	No.2 Relay + No.2 Optomos (ML) Outputs																									
AO2-0420	No.2 0÷20 or 4÷20mA Analog Outputs																									
DI4-TR	No.4 Digital Inputs for Voltage-Free Contacts																									
TCOM	No.2 programmable RS232/485 ports																									
PROFI	Profibus DP Interface																									
LON	Lonbus Interface																									
ETH	10/100 Ethernet Interface																									

Subject to change without notice



**ENERGY MEASUREMENT
AND CONTROL**

ALGODUE ELETTRONICA s.r.l.
Via Passerina, 3/A
28010 FONTANETO D'AGOGNA
(NO) ITALY

Tel: +39 0322 89864 - 89307
Fax: +39 0322 89871
E-mail: info@algodue.com
Website: www.algodue.com

