

# UPM307

## DIN 96x96 Compact LCD Power Meter



- Depth 60mm Only
- True RMS Measurement
- More than 100 Electrical Parameters Displayed
- Neutral Current Monitoring
- Fully Bi-Directional Four Quadrants Readings
- High Contrast Graphic LCD Display with a Very Large Viewing Area
- Power and Current Demand Calculation During User-Definable Time Period
- THD and Individual FFT Harmonic Analysis up to 15<sup>th</sup> Order
- No PTs Required up to 600 (750)V<sub>AC</sub>
- Programmable CT and PT Ratios
- Easy to Use



### General Description

The UPM307 is a digital meter able to measure the electrical parameters on three-phase systems.

It provides accurate measurements even by distorted waveform.

The backlighted LCD display is very large and highly efficient, therefore it guarantees perfect visibility in all light conditions.

A simple menu structure makes the instrument easy to use and allows a quick check of the measured parameters.

The working parameters can be easily set up by instrument keypad.

The RS232 or RS485 serial communication port allows to transfer the three-phase electrical parameters from the instrument.

The WINTOOL, free of charge software, allows to show on a PC all the measured values and to program the instrument in a fast way.

The UPM307 replaces multiple analog meters as well as single function meters such as voltmeters, ammeters, wattmeters, varmeters, frequency-meters, powerfactor-meters, energy-meters, etc.

The UPM307 is a compact, cost effective meter operating both as a stand-alone device or as an integral part of a more extensive energy monitoring and management network.

WINTOOL Communication Software  
available for free on the Web

### Benefits

- The UPM307 is the low cost solution for monitoring of all the main electrical parameters.
- It provides peak average current and power demand information. This data is essential to work out proper strategies aimed at avoiding uncontrolled power peaks and consequent penalties.
- The UPM307 being ultra-compact and easy to mount is suitable for replacing conventional meters. The UPM307 provides powerful capabilities not offered by traditional analog meters.
- The UPM307 allows time and cost saving on mounting, compared to many individual single-function instruments.
- Via communication port it is possible to read and log on a PC all the readings. The remote connection allows to generate on a PC consumption profiles, logged values trends, cost allocation and reports as well as to identify critical values.

### Applications

- Switchboards, gensets, motor control centers, etc.
- Power monitoring & control systems
- Individual machine load monitoring
- Demand management
- Harmonics monitoring
- Remote metering and cost allocation

**Main Features**

**Measurements**

- Single-phase and three-phase 3-wire or 4-wire unbalanced load operation
- True RMS metering provides accurate measurement even for distorted waveform
- Fully bi-directional, four-quadrant readings
- More than 100 electrical parameters measured (instantaneous, demand, peak values, energies, etc.)
- THD calculation on voltage and current
- Optional FFT analysis up to 15th order
- Direct measurement up to 600 (750) $V_{AC}$
- Programmable 1A / 5A current full scale.
- Programmable CT & PT ratios
- Optional temperature indication

**Front Panel Display**

- High contrast bright, easy to read, graphic LCD display with a very large viewing area of 79 x 44 mm
- White LED display backlighting with 100.000 hours minimum lifetime
- Up to four parameters displayed on the same page
- Password protected setup and resetting operations

**Communication**

- RS232 or RS485 optoisolated communication port
- Modbus protocol or standard ASCII protocol
- Communication speed programmable up to 57,600 bps
- Optional built-in Profibus, Lonbus interfaces

**Inputs & Outputs**

- Two digital outputs for energy pulsing or for alarm tripping
- Optional one digital input for tariff sincronization

**Other**

- Real time waveform downloading via communication port. This function allows to represent graphically on the PC the three voltages and the three currents with 128 samples per cycle.
- Optional internal interface for Rogowski transducer. Available range 200, 1000 or 3000A on request.
- Three selectable languages: English, German, Italian

INSTANTANEOUS MEASUREMENTS		
PHASE VOLTAGE	$V_{L1-N} - V_{L2-N} - V_{L3-N}$ [V]	●
LINE VOLTAGE	$V_{L1-L2} - V_{L2-L3} - V_{L3-L1}$ [V]	●
SYSTEM VOLTAGE	V [V]	●
LINE CURRENT	$I_{L1} - I_{L2} - I_{L3} - I_N$ [A]	■
SYSTEM CURRENT	I [A]	■
POWER FACTOR	$PF_{L1} - PF_{L2} - PF_{L3}$	●
SYSTEM POWER FACTOR	PF	●
DISPLACEMENT POWER FACTOR (COS Ø)	$DPF_{L1} - DPF_{L2} - DPF_{L3}$	○
APPARENT POWER	$S_{L1} - S_{L2} - S_{L3}$ [VA]	■
SYSTEM APPARENT POWER	S [VA]	■
ACTIVE POWER	$P_{L1} - P_{L2} - P_{L3}$ [W]	■
SYSTEM ACTIVE POWER	P [W]	■
REACTIVE POWER	$Q_{L1} - Q_{L2} - Q_{L3}$ [var]	■
SYSTEM REACTIVE POWER	Q [var]	■
FREQUENCY	f [Hz]	●
DEMAND (AVERAGE VALUES)	$3 \times I_{AVG} - S_{AVG} - P_{AVG}$	●
VOLTAGE THD	$THD_{L1} - THD_{L2} - THD_{L3}$ [%]	●
CURRENT THD	$THD_{L1} - THD_{L2} - THD_{L3}$ [%]	●
FFT ANALYSIS 15 <sup>TH</sup>	[% , V, A]	○
PHASE REVERSAL	123 / 132	●
TEMPERATURE	T [°C, F]	○
TIME COUNTER	Elapsed Time [Hours]	○
STORED DATA		
SYSTEM ACTIVE ENERGY	[Wh]	■
SYSTEM APPARENT ENERGY	[VAh]	■
SYSTEM LAGGING REACTIVE ENERGY	[varh ind]	■
SYSTEM LEADING REACTIVE ENERGY	[varh cap]	■
H/L TARIFF REGISTERS + RTC	[Wh, VAh, varh]	○
PEAK VALUES	$3 \times V_{L-N} - 3 \times V_{L-L} - 3 \times I_L - 3 \times I_{AVG} - I_N - P_{AVG} - S_{AVG}$	●
● = Standard    ■ = Bi-directional value    ○ = Optional		

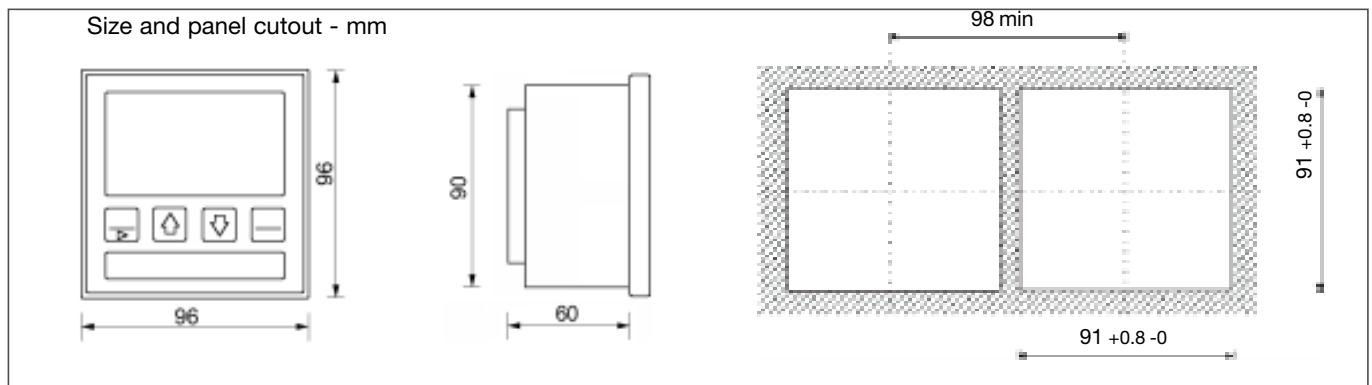

**Specifications**

**Power supply**

Rated voltage: 230 Vac (or 115 Vac on request) +15% -20%  
 Consumption: 2VA max

**Voltage inputs**

Maximum measurable voltage: 600 (750)Vac max L-L  
 Input impedance: >1.3 MOhm  
 Burden: max 0.15 VA per phase  
 Frequency: 45 - 65 Hz

**Current inputs**

Rated current (Ib): 1 / 5 ARMS programmable  
 Min / max measurable current: 20 mA / 7 ARMS  
 Maximum overload: 10ARMS continuous - 100 ARMS for 1 sec.  
 Input impedance: 0.02 Ohm approximately  
 Burden: max 0,5 VA per phase  
 Insulation voltage: 150 Vac max between phases

**Typical accuracy**

Voltage: ± 0.2% reading ± 0.1% full scale  
 Current: ± 0.2% reading ± 0.1% full scale  
 Active power: ± 1% reading ± 0.2% full scale (PF=1)  
 Power factor: ± 1% reading (0.5 inductive - 0.8 capacitive)  
 Active energy: ± 1% reading (0.5 inductive - 0.8 capacitive)  
 Frequency: ± 0.05% reading ± 1 digits from 45 to 65 Hz

**Display and operating controls**

Display: Back-lighted graphic LCD 132 x 64 dots  
 Keypad: 4 push-buttons

**Communication port**

Type: RS232 or RS485 on request, optoisolated  
 Baud Rate: 300 to 57600 bps

**Real Time Clock**

Type: with battery backup  
 Accuracy: ± 30 ppm

**Digital outputs**

Type: No.2 optoisolated (50V-100mA<sub>DC</sub>)

**Digital input**

Type: No.1 optoisolated (19÷130V<sub>AC-DC</sub>)

**Environmental conditions**

Operating temperature: from -10 °C to +60 °C  
 Storage temperature: from -25 °C to +75 °C  
 Relative humidity: 80% max. without condensation

**Mechanical characteristics**

Material: Plastic enclosure  
 Protection degree: IP54 (front panel); IP20 (terminals)  
 Terminals: Conductors 2.5mm<sup>2</sup>  
 Size / Weight: 96 x 96 x 60 mm or 96 x 96 x 105 mm  
 500 gr max, depending on the configuration

**Standards compliance**

Safety: 73/23/EEC and 93/68/EEC directives, EN61010.1 safety standard  
 EMC: 89/366/EEC directive and following modifications 93/31/EEC and 93/68/EEC , EN50081-2, EN50082-2, EN61326/A1

**TYPICAL WIRING DIAGRAMS**

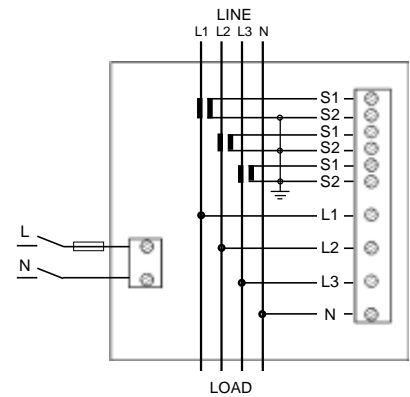

**3-Phase 4-Wire up to 600V**

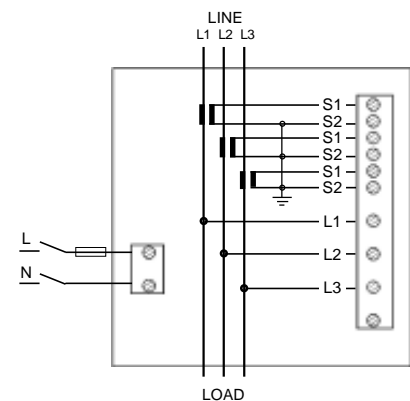

**3-Phase 3-Wire up to 600V**

For two CTs only, see the diagram below

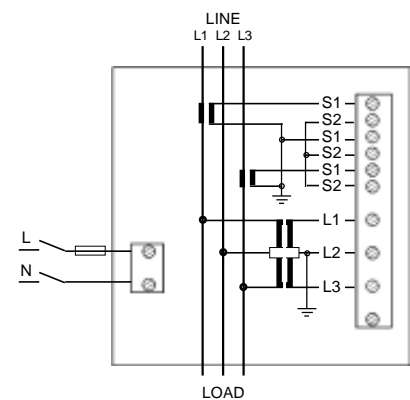

**3-Phase 3-Wire above 600V**

**Wiring diagrams**

The UPM307 offers a very good connection versatility for measuring inputs. In addition to the standard 3 and 4-wire wiring diagrams (see on previous page), special connections are available, all of them programmable from the menu.

The additional wiring diagrams are the results of the on-field experience, focused sometime to simplify the connection, especially when the load is balanced or when an high accuracy is not requested.

**3-Phase 3-Wire 1CT**

Simplified wiring diagram for balanced loads with only one current transformer. The measuring error is proportional to the current unbalance.

**3-Phase 3-Wire 1V - 1CT**

Simplified wiring diagram for balanced loads with only one current transformer and one voltage connection. The measuring error is proportional to the current and the voltage unbalance. Useful for time / cost saving.

**Single Phase**

Single phase wiring diagram up to 400V<sub>Ac</sub>.

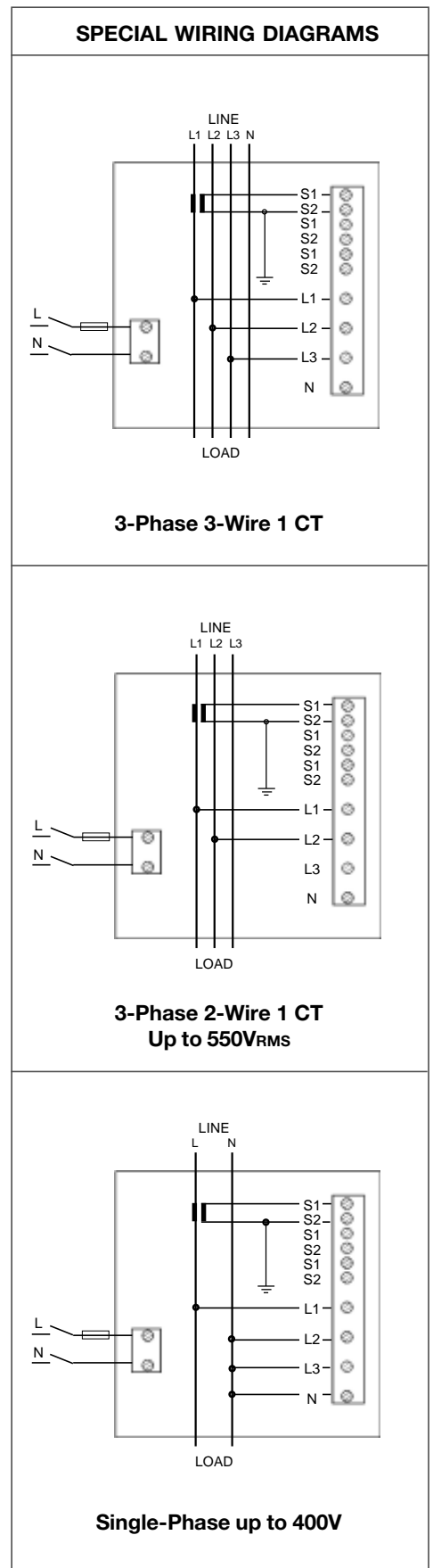

**WINTOOL - Communication and Monitoring Software**



- For Microsoft Windows environments
- User-friendly
- Real-time Data Viewing
- Quick Instruments Setup
- Parameters verification
- Available for free on the Web

**DOWNLOAD IT FROM OUR WEB SITE**

WINTOOL software enables the power meters to be connected to a PC for measured data viewing. It allows an easy and fast way to set the instrument parameters by a desktop or portable PC.

The remote monitoring is carried out through serial communication port (RS232 or RS485) or Ethernet TCP/IP / Internet connection.

It is a multilanguage software, at present the available languages are: English, German, Italian, French, Spanish, Hungarian.

It is the “free-of-charge” solution to configure and display the readings from instruments with or without display.

**Real-time Data Viewing**

WINTOOL displays real-time values from the instruments.

The available information includes:

- Real time values (voltage, current, power, PF, power)
- Energy consumption values (active, reactive and apparent)

**Quick instrument Setup**

Because of user-friendly approach, the power meters can be configured more quickly by the WINTOOL software than by using keypad.

The software shows the hardware configuration of the connected meter.

A SEARCH function allows to automatically detect the connected meter without the need of writing the serial number.

**ORDERING INFORMATION**

ALL A [ ] [ ] [ ] [ ] X [ ] [ ] [ ] X X [ ]

**UPM307**

**Reserved**

**User's Manual Language**

- D = German
- I = Italian
- U = English

**Communication Protocol**

- X = None (without serial port)
- B = ASCII Standard
- C = Modbus
- L = Lonbus interface (2)
- P = Profibus interface (2)

**Aux Power Supply**

- A =  $115V_{AC} +15\% -20\%$
- B =  $230V_{AC} +15\% -20\%$
- C =  $65 \div 250V_{AC} / 90 \div 250V_{DC} (3)$
- R =  $19 \div 60V_{DC} (3)$

**Serial Port**

- X = None
- 2 = RS232
- 5 = RS485

**Memory**

- X = None

**Firmware Options**

- 5 = Basic version with THD on V and I (1)
- 3 = Harmonics to 15<sup>th</sup> + DPF

**Hardware Options**

- X = None
- T = RTC +H/L Tariff Counters
- W = RTC + H/L Tariff Coun.+ Harmonics to 15<sup>th</sup> + DPF

**Other**

- X = None
- P = Rogowski inputs 200A
- R = Rogowski inputs 1000A
- S = Rogowski inputs 3000A
- C = Rogowski inputs (customized value)
- T = Temperature sensor

**Inputs**

- X = None

**Analog Outputs**

- X = None

**Digital Outputs**

- X = None
- 2 = Basic version with No.2 on-board optoisolated outputs NPN type
- 3 = Basic version with No.2 on-board optoisolated outputs PNP type

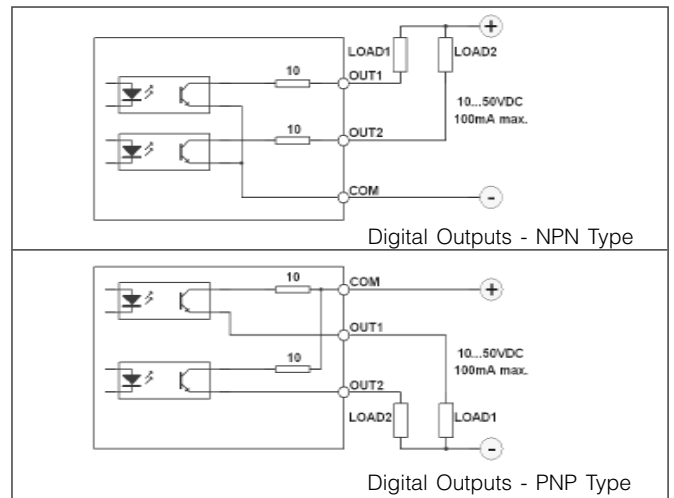

**NOTES**

- (1) The basic instrument configuration includes:
- Power Supply  $230V_{AC}$  (or  $115V_{AC}$ )  $+15\% -20\%$
  - No.2 Optoisolated Outputs ( $50V - 100mA_{DC}$ )
  - THD % on Voltage and Current

- (2) This communication option modifies the following features of the instrument:
- the depth increases from 60mm to about 100mm
  - the range of the power supply becomes  $65 \div 250V_{AC} / 90 \div 250V_{DC}$  (or  $19 \div 60V_{DC}$  on request)
- (3) This option increases the depth of the instrument from 60mm to about 100mm

Subject to change without notice



**ENERGY MEASUREMENT AND CONTROL**

ALGODUE ELETRONICA s.r.l.  
Via Passerina, 3/A  
28010 FONTANETO D'AGOGNA  
(NO) ITALY

Tel: +39 0322 89864 - 89307  
Fax: +39 0322 89871  
E-mail: info@algodue.com  
Website: www.algodue.com

